

# Passive Magnetic Bearings with Mantelfeld-Structure

Friedbert Schaefer\*

Leo Drenkard Str. 1, D-97264 Helmstadt, GERMANY

7th International Symposium on Magnetic Suspension Technology

Abstract. *The presented proposals for passive magnetic bearings are based on a new kind of magnetic field structure called “Mantelfeld”. The German name “Mantelfeld” was created by the author to characterise the substantial properties of the homopolar field, that exists only in a defined circular region of a rotational symmetric ring. Passive Axial Mantelfeld-Bearings combined with Passive Radial Mantelfeld-Bearings are supposed to manage a stable suspension without mutual destabilisation. The designs allow great diameters and promise high efficiency because the exciting coils can be made of superconducting material and no electronics are required to operate them.*

Keywords: homopolar, superconducting, Mantelfeld, Earnshaw’s theorem

## 1. Introduction

The presented proposals for passive magnetic bearings are all based on a new kind of magnetic field structure called “Mantelfeld”. The German name “Mantelfeld” was created by the author to characterise the substantial properties of the new magnetic field, that exists only in a defined circular region of a rotational symmetric ring. The Mantelfeld is analogue to the field of a coaxial cable, in which the inner conductor is hollow. You may imagine it like a hula-hoop, which contains the field in its plastic material surrounding a hollow volume with no or only a weak field. Change the plastic material into a ferromagnetic one, make one or more gaps in it and the “magnetic” structure turns into a “magic” structure:

Since 1842, scientists refer to Earnshaw [1], when they declare it is not possible, to stabilise the magnetic suspension of a rotor using permanent magnets only. The same prejudice exists versus the possibility of stable magnetical suspension by using electromagnetic devices

with constant currents.

Though all proposals made in this paper are theoretical and no experiment was made to confirm the new theory, it seems obvious that the Mantelfeld-Structure has the potential to disproof Earnshaw’s theorem.

In 1994 the author invented a homopolar machine with integrated magnetic bearings. The design has been extremely condensed using only one circular magnetic field for the motor/generator function and for the use of axial/radial magnetic bearings [2].

In 2001 another homopolar D.C. machine has been invented by the author using the same field structure (Mantelfeld) but different to Version 1994 the core is now made of iron or another ferromagnetic material. That machine is much less integrated and has the inherent property to work as an axial magnetic bearing [3].

That new-found bearing type is operated in attractive modus in contrast to the repulsive modus which was used in Version 1994. This idea of attractive operation is the basis for a complete set of compatible magnetic bearings:

## 2. A Strong Team of Bearing-Modules

The following designs are products of pure imagination. The designs are better to understand when you think in great dimensions.

The theory of excitation is principally the same in all modules.

One statement is important and should be kept in mind: In the gap of the Mantelfeld-Core the magnetic field is supposed to be homogeneous, not divergent. So it can be assumed that there is no malicious influence between axial and radial bearings.

### 2.1 Passive Axial Magnetic Bearing consisting of two Mantelfeld-Core Halves divided by an axially parallel gap (Mirrored C Type)

To make the production more convenient and to obtain more stiffness, the strictly circular Mantelfeld-circuit of the mentioned homopolar machine (Version 2001 [3]) was redesigned and got a rectangular sectional view (Fig. 1).

The magnetic flux in the core is excited by two concentric coils positioned in the background of the Mantelfeld-core opposite to the gap. The ferromagnetic core is between the two coils, encircles the coil closest to the gap, encircles a non-magnetic support structure and a hollow volume, which should be free of field in the ideal case, and separated by the gap the magnetic circuit closes through the second half of the core, which is a mirror image to the first half. The sectional view reminds to a core type transformer and the underlying theory is deduced from such transformers. Direct currents flow in the corresponding coils with the same amperage but in opposite directions and excite the Mantelfeld. The field strength is constantly high and can reach over two Tesla if the core material is excited up to its saturation limit. The strength of the bearing increases with the square of the field strength [4]. If the field strength is 2 Tesla, the working forces are 8-fold as strong as those of a permanent-magnet bearing in comparable dimensions according to System Juelich [4], which is usually operating at 0,7 Tesla. Leakage is minimised in the "circular" Mantelfeld, achieved by leading the flux almost completely through ferromagnetic

material. The design can further be optimised; for instance, it may be better to make the corners round or to operate the corresponding coils with different amperage. It may also be advantageous to distribute the windings of the outer coil in a manner that encircles the core in the outer periphery. All arrangements which minimise flux leakage can increase the efficiency of the bearings. Computer aided design should be helpful to find an optimal design.

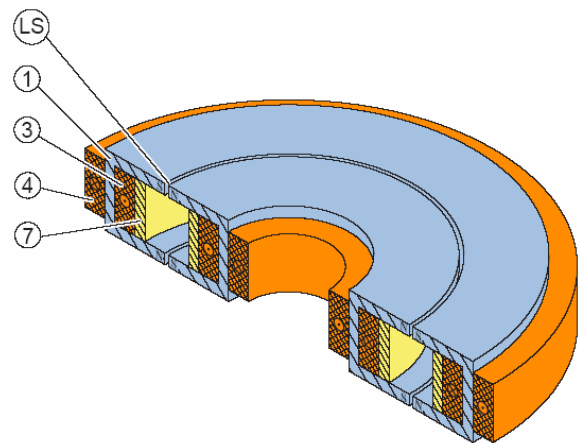

Fig.1 Module 1: Schematic view of a Passive Axial Mantelfeld-Bearing

The Illustration in Fig.1 shows two halves of a common Mantelfeld-core facing each other at a concentric gap. Along the circumference of the gap the unlike poles attract each other. The massive iron core does not allow a mechanical contact if there exists a radial bearing which guarantees the concentric arrangement of the two halves. Even when an external load causes a minimal radial deposition, the system is not animated to increase the narrowing of the gap at one point, because it would mean an increase of the local reluctance on the opposite side of the structure.

It is obvious that the system resists automatically against axial disposition. The ferromagnetic material of the core does not have to be laminated. No eddy currents are created by the homopolar and homogeneous field. Along the circumference the rotor sees everywhere the same strong field. By the way it doesn't matter

which half of the Mantelfeld-Core rotates and which is fixed. Both, the rotating and the fixed half, or only the fixed one, can be excited by an inner and an outer coil. Of course it is much easier to have the coils only on the fixed part. In that case, the rotating “half” of the core can be made very simple as a naked return path and does not have to be formed as deep as the other half.

## 2.2 Passive Radial Mantelfeld-Bearing (Clamp Type)

For the radial stabilisation and to prevent the rotor from tilting, two passive radial Mantelfeld-Bearings according to Fig.2 can be used.

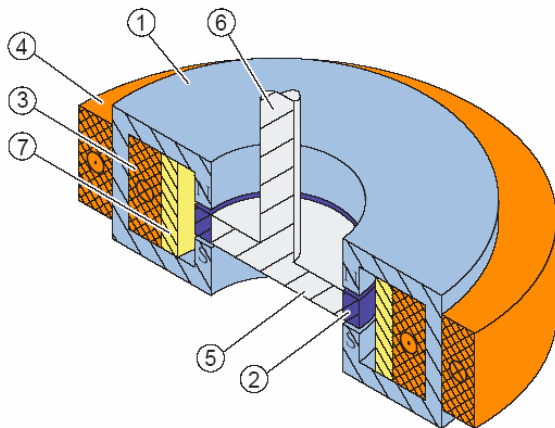

Fig.2 Module 2: Schematic view of a Passive Radial Mantelfeld-Bearing

Here is a ferromagnetic ring **2** magnetically tied up in the Mantelfeld-Circuit. The inner and outer exciting coils are arranged far enough from the gap, so that the place between the inner coil and the gap is almost free from flux leakage. The rotor shaft is made of non-magnetic material. The system resists automatically to radial loads attacking the rotor in radial direction, because a radial displacement would mean an increase of the reluctance in that module. Small axial displacements are without influence to the total reluctance in that module. No

destabilisation effects occur in the axial module.

An Axial Mantelfeld-Bearing according to Fig.1 in combination with two Radial Mantelfeld-Bearings according to Fig.2 should be able to suspend a rotor stable in all directions.

## 2.3 Passive Axial Magnetic Bearing “Clamp Type”

The principle of the radial bearing in 2.2 can easily be transferred to an alternative axial magnetic bearing, which is shown in Fig.3

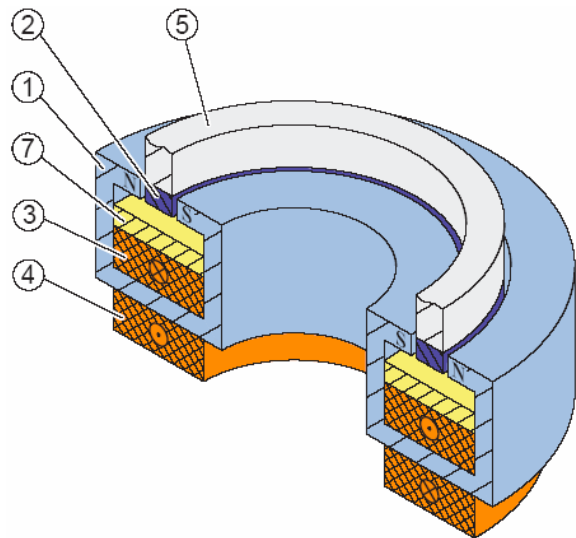

Fig.3 Module 3: Schematic view of a Passive Axial Mantelfeld-Bearing deduced from 2.2

The same logic is valid as in 2.2. The radial gap is changed in an axial gap.

That version is an alternative to the module described in 2.1 and is equivalent to that. For special application it may be preferred. An important application is shown in 2.4 and 2.5 if this module is combined with module 4.

## 2.4 Axial/Radial Magnetic Bearing Module “Mirrored U Type”

The Mirrored C Type radial bearing, shown in Fig.1 can be transposed into a Mirrored-U-Type bearing, which can be used as a passive radial bearing and simultaneously as an axial bearing, when further arrangements are implemented. (Fig.4).

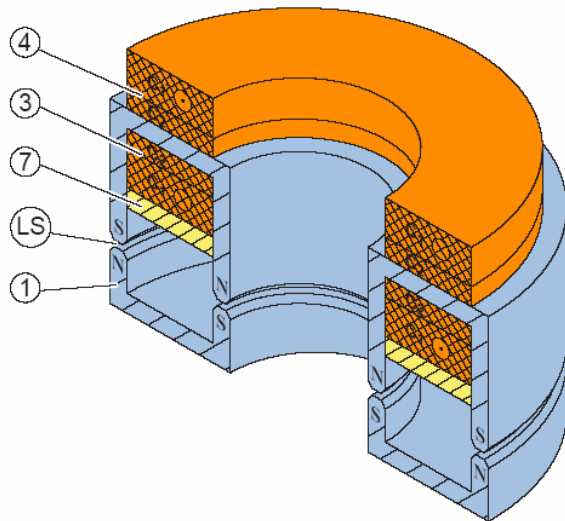

Fig.4 Module4: “Mirrored-U-Type” axial/radial magnetic bearing with active elements.

Several different arrangements are disposable to stabilise the axial direction:

- A preferred application of that module is a vertically operated flywheel. In that application the superior part of the core is excited by two inner coils and two outer coils. One of the inner coils and the corresponding outer coil carry Direct Current with constant amperage. The currents in the other coils are computer controlled and the amperage depends on the distance between the two core-halves. The coils with constant currents have to compensate the gravity force of the inferior core-half.
- The controlled coils must stabilise the equilibrium.

- The axial bearing can also be stabilised passively when combined with a passive axial magnetic bearing according Fig.1 or Fig.2. Using that arrangement, active controlling can eventually become unnecessary.
- Last but not least, the Mirrored-U Type bearing can be fused with a Clamp Type axial bearing. That fusion is illustrated in Fig.5

## 2.5 Axial/Radial Mantelfeld Bearing with flux ramification

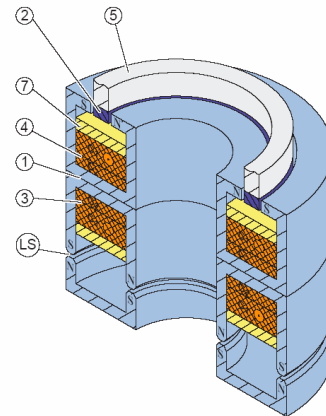

Fig.5 Module 5: Fused Mantelfeld-Bearing with flux ramification

The sectional view reminds to the sectional view of a shell type transformer. In addition to analogue advantages (the outer coil is no more outside), the design has additional advantages: Symmetric conditions are created between the corresponding exciting coils; Leakage is minimised and Electromagnetic Compatibility (EMC) is maximised.

If the inferior (rotating) core-half is mechanically connected with the superior rotor **5**, in conjunction with a further passive radial Mantelfeld-Bearing on the top side of the system (not shown in Fig.5), perhaps no electronics are required for a stable levitation of the rotating parts.

### 3. Conclusion and Outlook

All of the published designs of Mantelfeld-Bearings promise enormous advantages:

- Maximum forces can be obtained by magnetizing the Mantelfeld-core up to the limit that is given by the saturation of the ferromagnetic material.
- The need for computers and sensors is minimised. The stabilisation works mostly automatically and passively.
- Radial stability can be produced without destabilisation of the axial stability and vice versa.
- The homopolar, rotary symmetric arrangement of the magnetic flux increases efficiency because eddy currents are avoided.
- Direct Current with constant amperage is preferred to operate the bearings.
- The current carrying windings of the exciting coils can be made of high temperature superconducting (HTS) material. Even great devices with diameters in the order of several meters can be built without ohmic losses.
- The Mantelfeld-core of the stator and the rotor can be made of massive, unlaminated ferromagnetic material with high saturation.
- Nearly no limits exist in the order of magnitude.
- Flywheels with ultrahigh capacity can be built. The stored energy of a flywheel increases with the square of the distance, in which the rotating mass is located in relation to the centre of rotation. Centrifugal forces decrease proportional to that distance.
- Electromagnetic compatibility (EMC) is an intrinsic property of the Mantelfeld-structure.
- Small bearing devices can be made by injection moulding technologies using plastic magnetic materials.

- In combination with a Mantelfeld Homopolar Machine according to [3] and a Mantelfeld Homopolar Machine according to [2] a rotating, high efficient Direct Current Transformer can be created.

### 4. Acknowledgement

Thanks to Alexander Haug for helpful linguistic and stylistic advice.

### 5. References

- [1] Earnshaw, S.; "On the nature of the molecular forces which regulate the constitution of the lumiferous ether". Trans. Camb. Phil. Soc. 7 (1842), 97-112
- [2] Schaefer, F. "Gleichstrom-Motor mit Ringscheibenlauerer" Pat. Application DE 44 17 144
- [3] Schaefer, F. "Flossenlose Mantelfeld Homopolarmaschine mit integriertem Magnetlager" Pat. Appl.: DE 101 64 435
- [4] Fremerey, J.K. Internet Document [www.fz-juelich.de/zat/magnet/0b30.pdf](http://www.fz-juelich.de/zat/magnet/0b30.pdf)

Contact author: [fribb@t-online.de](mailto:fribb@t-online.de)